

To the Installer:

Please attach these instructions next to the water heater.

To the Consumer:

Please read these and all component instructions and keep for future reference.



Solar Indirect Water Heater Instruction Manual

Warranty, Registration Card and Parts List are included.
Homeowner: Please remember to return the Registration Card!

⚠ WARNING

Improper installation, adjustment, alteration, service or maintenance can cause serious injury or property damage. Refer to this manual. For assistance or additional information, consult a qualified installer or service agency.

⚠ CAUTION

The recommended temperature for normal residential use is 120°F. The dial on the aquastat does not always reflect the out-coming water temperature, which could occasionally exceed 120°F. The variation in out-coming temperature could be based on factors including but not limited to usage patterns and type of installation. Test your water at the tap nearest to the water heater.

⚠ WARNING

Hotter water increases the risk of scald injury. Before adjusting the water temperature setting, read this instruction manual. Temperatures at which injury occurs vary with the person's age and the length of exposure.

The slower reaction time of children, elderly, and physically or mentally challenged persons increases the scalding hazard to them. It is recommended that lower water temperatures be used where these exposure hazards exist. Such households may require a temperature setting less than 120°F to prevent accidental contact with hot water.

To lower water temperature use point-of-use temperature limiting devices.

⚠ WARNING

Water heater blankets are not recommended and will void the warranty.

THIS MANUAL HAS BEEN PREPARED TO ACQUAINT YOU WITH THE INSTALLATION, OPERATION, AND MAINTENANCE OF YOUR WATER HEATER AND TO PROVIDE IMPORTANT SAFETY INFORMATION.

INSTALLER RESPONSIBILITIES

Please read all instructions thoroughly before installing or placing the heater into service. This unit must be installed by licensed or authorized installers, or technical personnel that service water heating equipment. The heater must be installed in accordance with all local codes and ordinances.

These instructions are a guide for the correct installation of the water heater. The manufacturer will not be liable for damages caused by failure to comply with the installation and operating instructions outlined on the following pages.

⚠ CAUTION

The recommended water temperature setting for normal residential use is 120°F/49°C.

HANDLING

Before uncrating, check for shipping damage. Report any damage to your carrier. Note damage on bill of lading or delivery receipt and file a claim.

FAILURE TO FOLLOW THESE INSTRUCTIONS OR ALL APPLICABLE BUILDING CODES AND REGULATIONS VOIDS THE WARRANTY ON THIS WATER HEATER.

Read all instructions thoroughly before attempting installation or operation of your water heater. Keep these instructions for future reference.

Local plumbing and electrical codes must be followed in the installation of this water heater. In the absence of a local code use the UNIFORM PLUMBING CODE and the NFPA Code. Local codes may supersede instructions in this installation manual.

These instructions are a guide for the correct installation of the water heater. The manufacturer will not be liable for damages caused by failure to comply with the installation and operating instructions outlined on the following pages.

IMPORTANT SAFETY INSTRUCTIONS

▲ WARNING

When using electrical appliances, basic safety precautions to reduce the risk of fire, electric shock, or injury to persons should be followed, including:

1. **READ ALL INSTRUCTIONS BEFORE USING THIS WATER HEATER.**
2. **This water heater must be grounded. Connect only to properly grounded outlet. See “GROUNDING INSTRUCTIONS” found on page 14.**
3. **Install or locate this water heater only in accordance with the provided installation instructions.**
4. **Use this water heater only for its intended use as described in this manual.**
5. **Do not use an extension cord set with this water heater. If no receptacle is available adjacent to the water heater, contact a qualified electrician to have one properly installed.**
6. **As with any appliance, close supervision is necessary when used by children.**
7. **Do not operate this water heater if it has a damaged cord or plug, if it is not working properly, or if it has been damaged or dropped.**
8. **This water heater should be serviced only by qualified service personnel. Contact nearest authorized service facility for examination, repair, or adjustment.**

SAVE THESE INSTRUCTIONS

TABLE OF CONTENTS

Section I: Specifications 4

Section II: General Information 6

Section III: Pre-Installation 9

Section IV: Installation 10

Section V: Operation 15

Section VI: Maintenance 16

Section VII: Troubleshooting 17

Section VIII: Parts List 18

Section IX: Warranty 21

SECTION I: SPECIFICATIONS

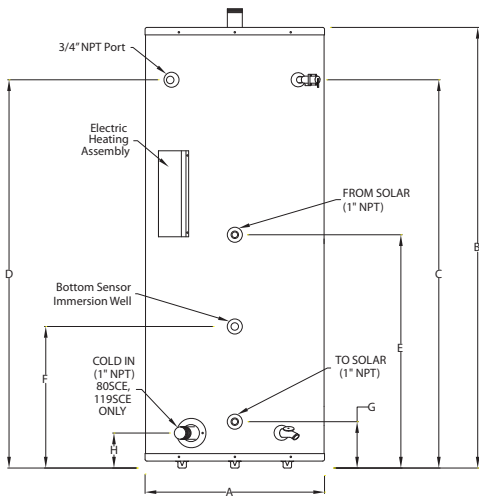
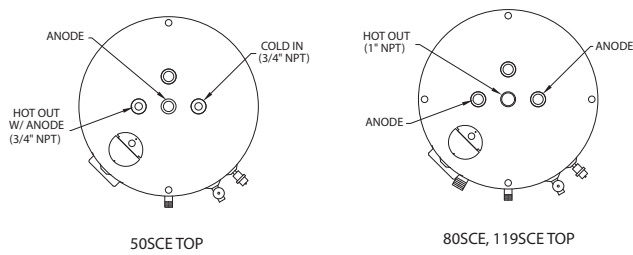

Figure 1: 50SCE, 80SCE, 119SCE

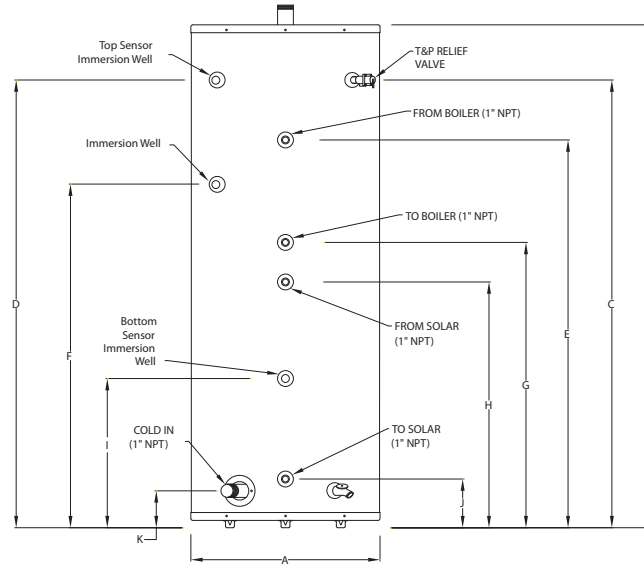
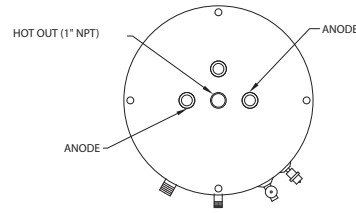

Figure 2: 80SDC, 119SDC

Table 1: Dimensions (SCE, SDC)

Model	A	B	C	D	E	F	G	H	I	J	K
50SCE	22"	48 1/4"	39 3/4"	39 3/4"	31 1/2"	16 3/4"	6 1/2"	n/a	n/a	n/a	n/a
80SCE	24"	64"	57 1/8"	57 1/8"	31 1/2"	19 1/4"	6 1/2"	5"	n/a	n/a	n/a
119SCE	28"	65"	57 3/4"	57 3/4"	33 3/4"	16 1/4"	8 3/4"	6 1/2"	n/a	n/a	n/a
80SDC	24"	64"	57 1/8"	57 1/8"	49 1/2"	46 7/8"	36 1/2"	31 1/2"	19 1/4"	6 1/2"	5"
119SDC	28"	65"	57 3/4"	57 3/4"	51 3/4"	49 1/8"	38 3/4"	33 3/4"	16 1/4"	8 3/4"	6 1/2"

80SDC, 119SDC available with electric heating backup (80SDCE, 119SDCE)

Foam insulation standard. **Pressures, all:** Test pressure = 300 PSI; Working pressure = 150 PSI

Electrical rating (where applicable): 4.5KW, 240V

WARNING: Installation should be in accordance with all national and/or local codes.

CAUTION: The recommended water temperature setting for normal residential use is 120°F. SolarStor recommends a tempering valve or anti-scald valve be installed and used according to the manufacturer's directions to prevent scalding.

SECTION I: SPECIFICATIONS (cont.)

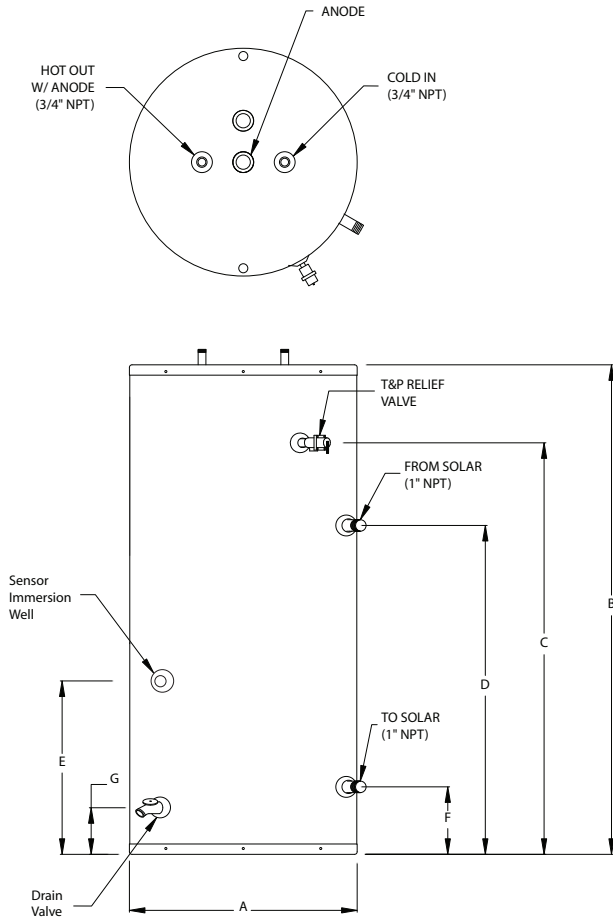

Figure 3: 40SC, 50SC

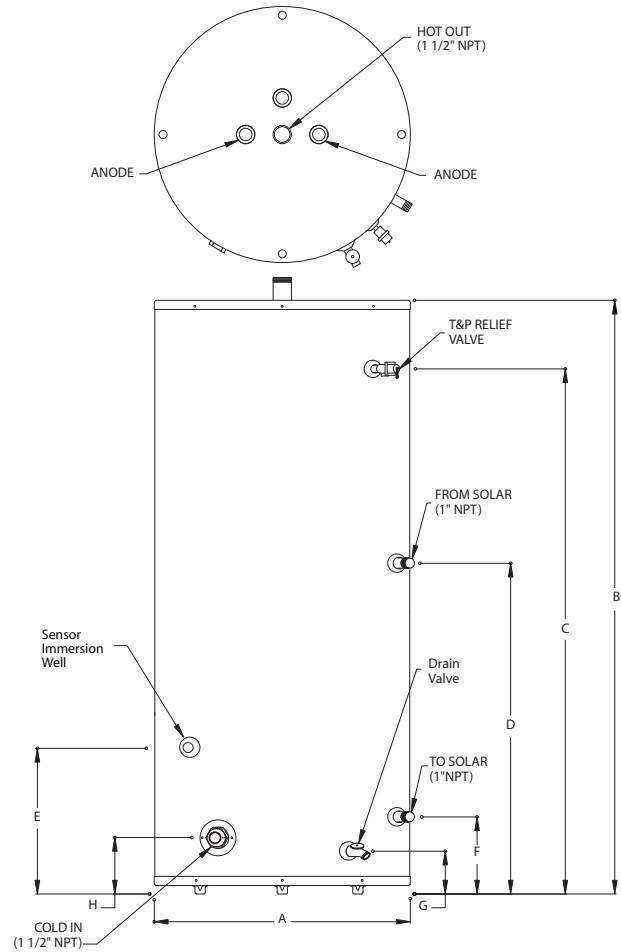

Figure 4: 80SC, 119SC

Table 2: Dimensions (SC)

Model	A	B	C	D	E	F	G	H
40SC	22"	42 1/4"	34 3/4"	31 1/2"	16 3/4"	6 1/2"	4 1/2"	n/a
50SC	22"	48 1/4"	39 3/4"	31 1/2"	16 3/4"	6 1/2"	4 1/2"	n/a
80SC	24"	64"	57 1/8"	33"	19 1/4"	8"	5"	5"
119SC	28"	65"	57 3/4"	33 3/4"	16 1/4"	8 3/4"	5"	6 1/2"

Foam insulation standard. **Pressures, all:** Test pressure, 300 PSI Working pressure, 150 PSI
Standard voltage, all: 120V, 60Hz, 1P.

WARNING: Installation should be in accordance with all national and/or local codes.

CAUTION: The recommended water temperature setting for normal residential use is 120°F. SolarStor recommends a tempering valve or anti-scald valve be installed and used according to the manufacturer's directions to prevent scalding.

SECTION I: SPECIFICATIONS (cont.)

Table 3: Capacity & Performance

Model	Actual Tank Volume (gal)	Coil Volume Solar/Boiler (gal)	Coil Surface Area Solar/Boiler (ft ²)	Coil Friction Loss* Solar/Boiler (ft.w.c.)	Electric Heating First Hour Rating (gal)	Standby Loss Rating (°F/hr)
50SCE	45	2.30/ -	11.78/ -	0.50/-	36	1.1
80SCE	75	2.76/ -	14.14/ -	0.60/-	40	0.8
119SCE	110	2.76/ -	14.14/ -	0.60/-	50	1.2
80SDC	73	2.76/1.84	14.14/9.42	0.60/0.40	-	0.8
119SDC	108	2.76/1.84	14.14/9.42	0.60/0.40	-	1.2

NOTES:

* Based on 5 GPM flow rate.

For SC model specifications, see SCE (with the exception of electric heating backup)

SECTION II: GENERAL INFORMATION

SOLAR WATER HEATER FUNCTION

The solar water heater is designed with an internal coil and backup electric heating element (where applicable). In lieu of an electric heating element, some models incorporate a second internal coil for backup heating. Furthermore, SDCE models are designed with a second internal coil and an electric heating element. A heating medium is passed through the solar panels and internal coil as long as there is an adequate temperature difference between the heating medium and stored water in the tank. The internal coil is located as close to the bottom as possible to facilitate the transfer of heat even at lower solar panel temperatures.

During periods of water flow through the water heater, hot water is drawn from the top of the heater and cold water is delivered to the bottom of the tank (by a diptube or bottom inlet). If the hot water demand should exceed the solar heat output or there is an insufficient temperature difference between the heating medium and stored water, the heating element thermostat will activate the electrical heating element for backup heat. When an additional internal coil is used for backup heating, an aquastat should be used for flow control in the backup heating loop. An aquastat immersion well is supplied on SDC and SDCE models.

Solar heat output from the internal coil will vary depending on outside conditions and the temperature of the stored water.

WATER TREATMENT/FILTRATION

In areas where poor water conditions are suspected (i.e. lime, iron, and other minerals), it is essential that the water be tested and appropriate action taken to prevent damage to the indirect heater and ensure the quality of the water.

SECTION II: GENERAL INFORMATION (cont.)

TEMPERATURE CONTROL

A solar controller (not provided) shall be used in conjunction with the solar water heater to run all solar components in the heating system. The solar controller will be connected to two thermistors that monitor lower and upper tank temperature. In some cases, only one thermistor (near the bottom of the tank) will be used. The proper temperature setting for domestic hot water use is 120°F/49°C.

The solar water heater is equipped with a backup electrical heating element and adjustable thermostat. The thermostat is located behind the access cover on the side of the water heater. If the solar system cannot satisfy the user demand, the electric element will energize and heat the water until the thermostat is satisfied. An ECO (electrical cut-off) is included as part of the temperature control and is designed to cut off power to the heating element in the event the water in the tank reaches 180°F. The ECO is a safety feature on the water heater and cannot be adjusted. In the event that the ECO opens, the control must be manually reset with the stored water temperature below 180°F.

The thermostat is factory set at 120°F. See Table 7 for thermostat letter and temperature relationships. If hotter water is required a tempering device or anti-scald device must be installed at the domestic hot water outlet of the heater or at the point of use. Table 4 details the approximate relationship of water temperature and time with regard to scald injury. It is important for the user to understand the necessity of tempering or anti-scald devices when using hotter water in domestic water heating systems.

⚠ CAUTION: Hot water in excess of 120°F can cause scalding!

SolarStor recommends a tempering valve or anti-scald valve be installed and used according to the manufacturer's directions to prevent scalding. Many state and local codes now require installation of these devices. The tempering valve or anti-scald valve will ensure potable water temperatures at the desired set point with a higher degree of accuracy.

Table 4: Scald Temperature/Time Relationships

APPROXIMATE TEMPERATURE/TIME RELATIONSHIPS TO SCALDING	
120°F	More than 5 minutes
125°F	1 ½ to 2 minutes
130°F	About 30 seconds
135°F	About 10 seconds
140°F	Less than 5 seconds
145°F	Less than 3 seconds
150°F	About 1 ½ seconds
155°F	About 1 second



SECTION II: GENERAL INFORMATION (cont.)

ANODE RODS

The anode rod is used as a sacrificial element within the volume of the storage tank. The purpose of the magnesium anode rod is to protect the inside of the tank against corrosion. Anode rods should be inspected twice in the first year and at least yearly once a time interval for inspection has been developed. Water conditions can influence the consumption rate of the anode rods. Please see the Maintenance section of this manual for instructions on how to change the anode rods in your SolarStor water heater.

▲ CAUTION

Hydrogen gas is produced in a hot water system served by the heater that has not been used for a long period of time (2 weeks or more). Hydrogen gas is extremely flammable. To reduce the risk of injury under these conditions, it is recommended that the hot water faucet be opened for several minutes at the kitchen sink before using any electrical appliance connected to the hot water system. When hydrogen is present, there will probably be an unusual sound such as air escaping through the pipe as the water begins to flow. There should be no smoking or open flame near the faucet at the time it is open.

TEMPERATURE AND PRESSURE RELIEF VALVE (T&P)

▲ CAUTION

To reduce the risk of excessive pressures and temperatures in this water heater, install temperature and pressure protective equipment required by local codes and no less than a combination temperature and pressure relief valve certified by a nationally recognized testing laboratory that maintains periodic inspection of production of listed equipment or materials, as meeting the requirements for Relief Valves and Automatic Gas Shutoff Devices for Hot Water Supply Systems, ANSI Z21.22. This valve must be marked with a maximum set pressure not to exceed the marked maximum working pressure of the water heater. Install the valve in an opening provided and marked for this purpose in the water heater, and orient it or provide tubing so that any discharge from the valve exits only within 6 inches above, or at any distance below, the structural floor, and does not contact any live electrical part. The discharge opening must not be blocked or reduced in size under any circumstances.

The T&P valve is factory installed. A discharge drain tube must be installed (responsibility of the installer) and shall terminate plain, not threaded, 6 inches above the floor drain. The drain tube material must be approved for temperatures of 120°F or greater and a pressure of 150 PSI or greater.

BACKFLOW PREVENTER (CLOSED LOOP SYSTEM)

Some local municipal codes and ordinances require the use of these devices on potable (domestic) water lines. Where backflow preventers are required, it will be necessary to install a **thermal expansion tank** (designed for used with potable water) in order to prevent pressure build up in the indirect heater and associated piping, which could cause the T&P valve to discharge. Follow the expansion tank manufacturer's recommendations when selecting a tank for your hot water system.

Note: Working pressure of the water heater is 150 PSI. Do not exceed 150 PSI.

SECTION III: PRE-INSTALLATION

LOCATION

⚠ CAUTION

This water heater must be located in an area where leakage of the tank, water line connections, or the temperature and pressure relief valve will not result in damage to the area adjacent to the water heater or to lower floors of the structure. When such location cannot be avoided, a suitable drain pan must be installed under the water heater. The drain pan depth must be suitable for draining and collecting water. The drain pan can be purchased from your plumbing professional. The drain pan must be piped to an adequate drain and all drain piping must be at least 0.75" in diameter and pitched for proper drainage.

⚠ CAUTION

DO NOT store or use gasoline or other flammable, combustible, or corrosive vapors and/or liquids in the vicinity of the water heater or any other appliance.

IF YOU SMELL GAS:

- DO NOT try to light any appliance.
 - DO NOT touch any electric switch; do not use any telephone in your building.
 - Immediately call your gas supplier from a telephone in another building. Follow your gas supplier's instructions.
 - If you cannot reach your gas supplier, call the fire department.
- DO NOT OPERATE THE APPLIANCE UNTIL THE LEAKAGE IS CORRECTED!**

⚠ CAUTION

Do not drop water heater or lay heater down on its side. Move the water heater into position by sliding or using an appropriately sized hand truck.

The solar indirect water heater must be installed indoors. Locate the water heater as close as practical to the solar heating system and leave sufficient clearances for servicing the heater. The entire solar heating system should be located as close as possible to points of hot water use for the fastest delivery of hot water. This water heater may be installed on combustible flooring. DO NOT install this water heater on carpeting.

See Tables 5 and 6 for combustible and service clearances.

Table 5: Clearance from Combustible Materials

Top	Sides	Front	Rear
0"	0"	0"	0"

Table 6: Recommended Service Clearances

Top	Sides (non-piping)	Side (T&P Relief Valve)	Front	Rear
12"	4"	6"	16"	0"

SECTION IV: INSTALLATION

WATER CONNECTIONS

▲ CAUTION

This water heater incorporates fittings that contain a nonmetallic lining. **DO NOT** apply heat to these fittings when making sweat connections to the heater. Sweat tubing to an adapter before securing adapter to any fittings on water heaters.

ALL PIPING SHOULD CONFORM TO LOCAL CODES AND ORDINANCES. It is highly recommended that unions and shut-off valves are installed at the potable water and heat exchanger connections to allow for isolation and/or movement during service. Installing a union on the potable outlet is of particular importance to facilitate replacement of the hot outlet/anode nipple on the 50 gallon model. In addition, all piping should be adequately insulated with an approved material to minimize heat loss.

POTABLE WATER CONNECTIONS

THE WATER HEATER MUST BE FILLED WITH WATER BEFORE CONNECTING ELECTRIC POWER.

- 1) Close the main water supply valve before continuing with the installation. After the main water supply is shut-off, relieve the water line pressure by opening a faucet. Once the pressure has been relieved, close the faucet. The “Cold” and “Hot” potable water connections are labeled on the water heater. Install a union and shut-off valve at both potable water connections. All piping should be $\frac{3}{4}$ ” diameter new copper or larger. A tempering valve or anti-scald valve should be installed at the potable water outlet and used according to the manufacturer’s specifications to prevent scalding.
- 2) If a backflow preventer is required in the cold water supply, a properly sized expansion tank must be installed to control thermal expansion. Do not operate the water heater in a closed system without installing a thermal expansion tank. Follow the expansion tank manufacturer’s recommendations when selecting a tank for your system.
- 3) Following installation of the water lines, open the main water supply valve and fill the water heater. Open several hot water faucets to relieve air from the system. After water is flowing through the faucets and the system is void of air, close the faucets and check for water leaks in the system.

SOLAR CONNECTIONS

▲ CAUTION

Temperature of the primary heat source medium (from solar collector or boiler) shall not exceed 200°F.

The outlet of the solar collector should be connected to the water heater at the “FROM SOLAR” fitting. The fitting labeled “TO SOLAR” should be connected to the solar return piping. It is recommended to install a union and shut-off valve at each solar connection. All pipe and fittings between the solar system and water heater should be $\frac{3}{4}$ ” diameter or larger.

SECTION IV: INSTALLATION (cont.)

PIPING DIAGRAMS

A piping diagram for a typical solar domestic water heating system based on an indirect water heater with electric heating backup is shown in Figure 5.

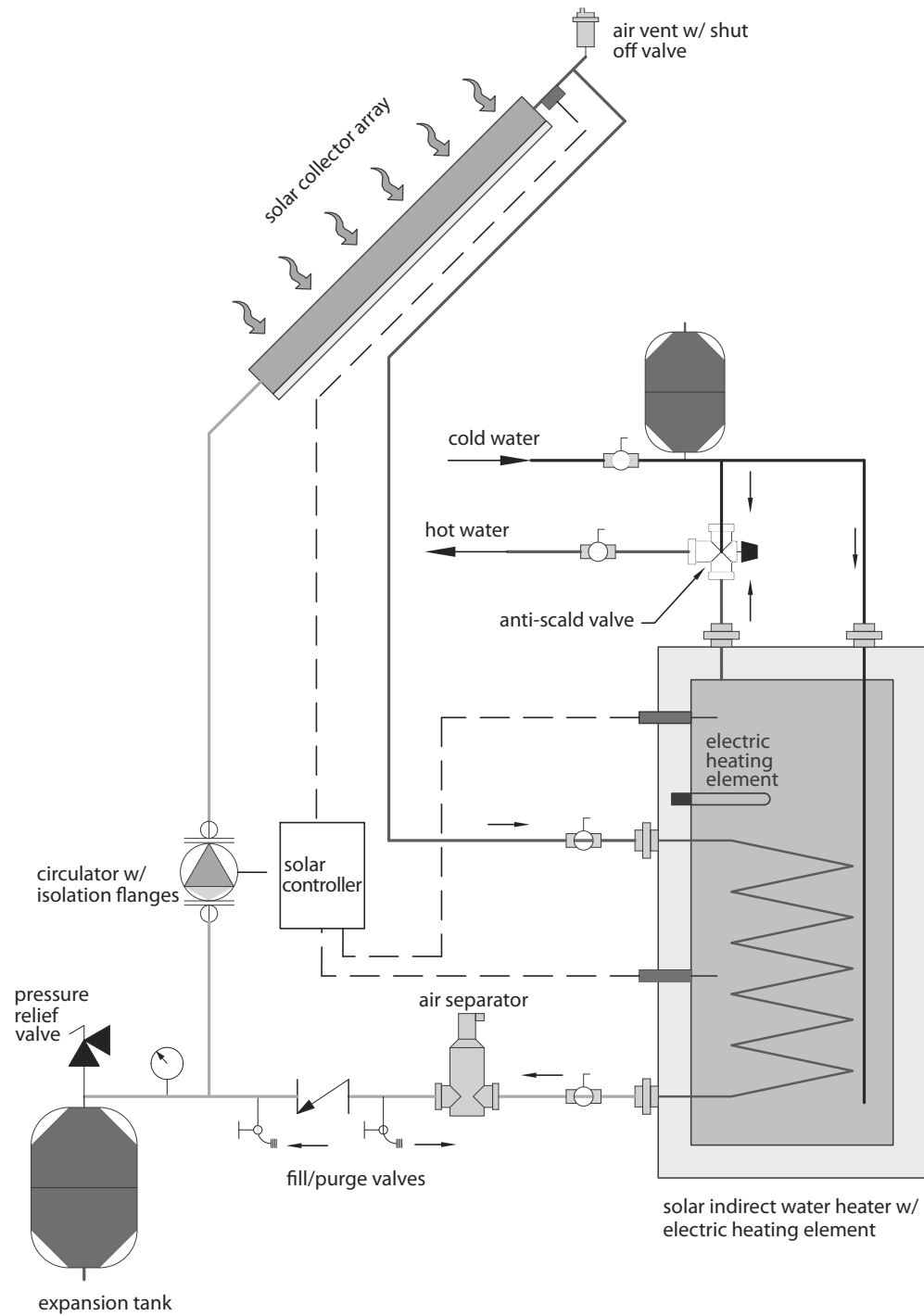

Figure 5: Single tank system with electric backup

SECTION IV: INSTALLATION (cont.)

A typical two tank system is shown in Figure 6. The two tank system is mainly used where a conventional water heater is already installed.

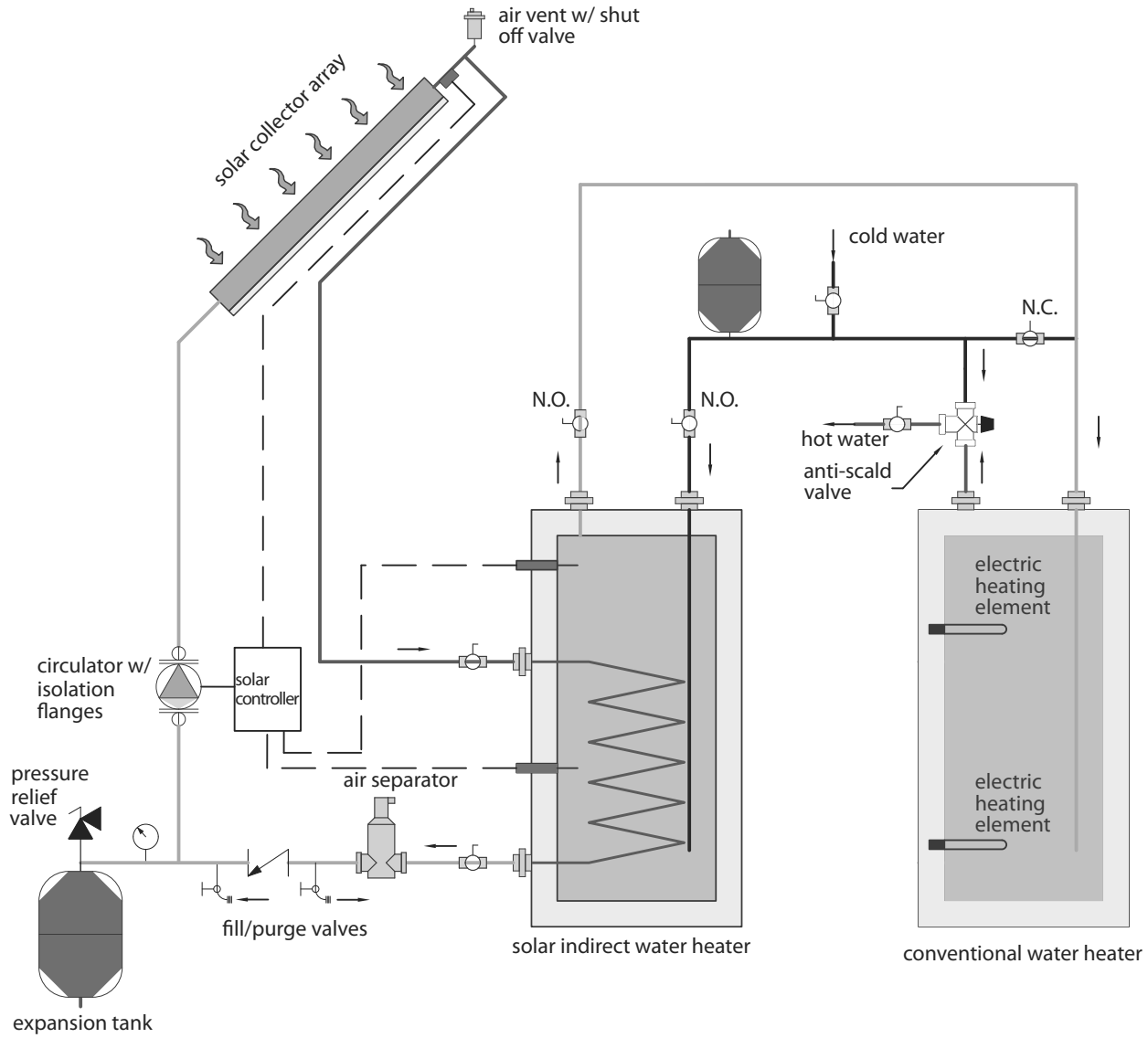

Figure 6: Two tank system with existing heater

SECTION IV: INSTALLATION (cont.)

Figure 7 shows an example of a domestic solar heating system based on an indirect water heater with two coils. The domestic water can be heated by the solar system as well as the boiler.

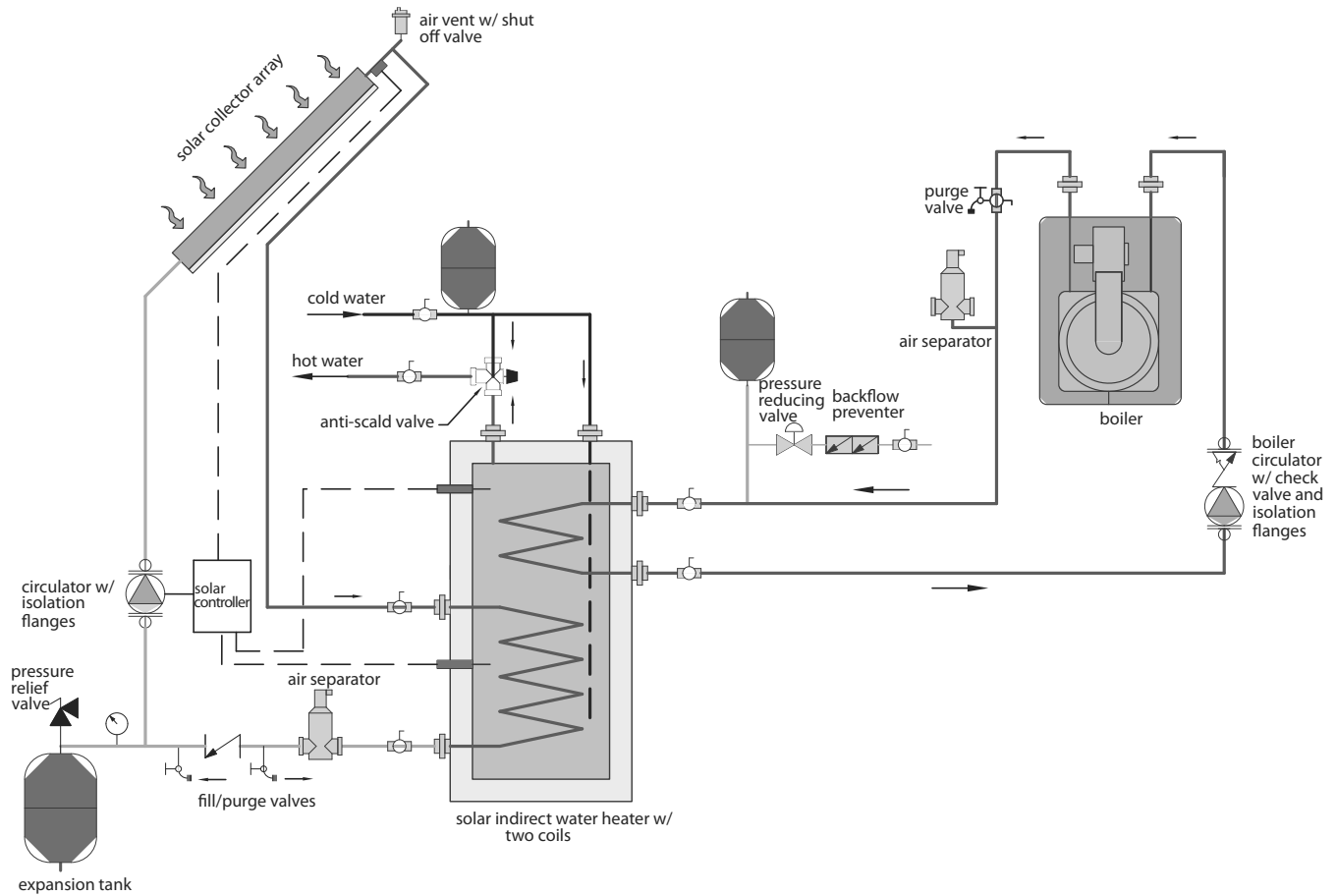

Figure 7: Single tank system with boiler backup

SECTION IV: INSTALLATION (cont.)

ELECTRICAL CONNECTIONS

⚠ DANGER

Confirm that all electrical connections are unpowered before installing or servicing electrical components/connections within the water heater.

⚠ WARNING

The water heater must be electrically grounded in accordance with local codes or, in the absence of local codes, with NFPA 70.

Failure to properly wire electrical connections may result in serious physical harm.

Electrical power may be from more than one source. Make sure all power is off before attempting any electrical work.

ELECTRIC HEATING ELEMENT (BACKUP)

THE WATER HEATER MUST BE FILLED WITH WATER BEFORE CONNECTING ELECTRIC POWER.

All electrical connections on the water heater must be made with copper conductors only. A separate branch circuit with copper conductors, over-current protection, and means for disconnection must be provided by qualified service personnel. The total wattage load and voltage requirements for the water heater are specified on the rating label located on the front of the heater.

The thermostat and electric heating element are pre-wired at the factory. A junction box is located at the top of the water heater. The junction box cover will accommodate a $\frac{1}{2}$ " or $\frac{3}{4}$ " electrical conduit connector. Two wires are located in the junction box (red and black) for connection to the branch circuit. See Figure 8 for a wiring diagram.

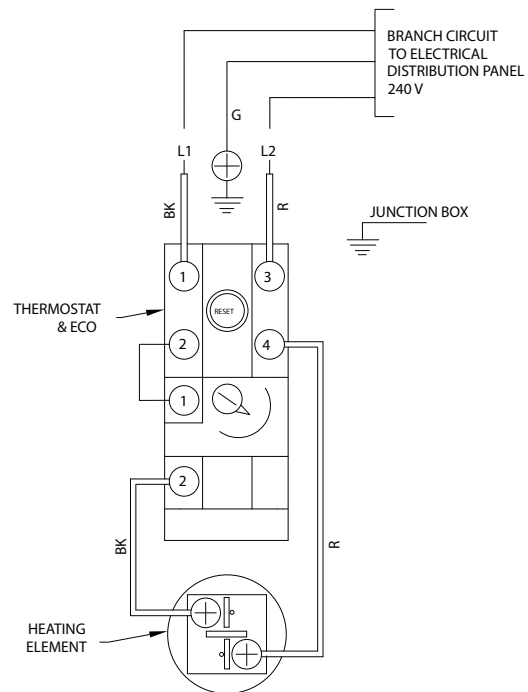

Figure 8: Thermostat and Heating Element Wiring

GROUNDING INSTRUCTIONS

A green screw (ground) is located in the junction box for proper connection to ground from the branch circuit.

SOLAR CONTROLLER AND THERMISTORS

Two locations for potable water temperature measurement have been provided. The factory installed immersion wells are designed to accommodate insertion of a thermistor. **The solar system controller and thermistors are not supplied with this water heater.**

SECTION V: OPERATION

INITIAL START-UP

Reference the solar collector installation instructions for proper start-up of the solar collector. Be sure that fluid flow in the solar system is established.

HEATING OPERATIONS

Condition 1: The minimum temperature difference (for heat transfer) between the potable water at the bottom of the tank and the solar collector is sensed by the solar controller. In addition, the tank temperature is below the maximum tank temperature setpoint (on solar control).

Action 1: The solar controller energizes a pump to flow fluid through the solar collector and heat exchanger. Heat is transferred to the potable water until the temperature difference is reduced to a desired value or the maximum tank temperature has been reached.

Condition 2: The heating element thermostat senses that the potable water temperature in the upper area of the tank drops below the thermostat set-point.

Action 2: The heating element is energized and heats the potable water to the set-point temperature, at which point the element is de-energized.

THERMOSTAT TEMPERATURE ADJUSTMENT

⚠ CAUTION

The temperature setting on the heating element thermostat shall not exceed 160°F. Likewise, the solar controller potable water temperature setting shall not exceed 160°F. Install a tempering valve or anti-scald mixing valve at the outlet of the water heater to ensure greater control over water temperatures at the point of use.

⚠ CAUTION

Turn off all power to the water heater before adjusting the heating element thermostat.

The heating element thermostat is factory adjusted to 120°F (“HOT” indicator setting). If thermostat adjustment is necessary, disconnect all power to the water heater and solar collector. Remove the access cover on the side of the water heater and remove the foam dam insert to expose the thermostat and heating element. The temperature knob can be adjusted with a screwdriver to a minimum temperature of 110°F and a maximum temperature of 160°F (labeled “VERY HOT”). See Table 7 for a listing of indicator setting and temperature relationships.

Table 7: Thermostat Temperature Settings

Indicator Setting	Temperature (°F)
• (min)	110
HOT	120
A	130
B	140
C	150
VERY HOT	160

SECTION V: OPERATION (cont.)

CAUTION

Hot water in excess of 120°F can cause scalding! The temperature at which injury occurs varies with the person's age and the time of exposure. The slower response time of disabled persons increases the hazards to them. NEVER allow small children to use a hot water tap. NEVER leave a child or disabled person unattended in a bathtub or shower.

Replace the foam dam insert and access cover after adjusting/inspecting the thermostat.

If the thermostat temperature setting (or anti-scald mixing valve) was adjusted, check the water temperature at a faucet. Flow enough water through the faucet to ensure that the faucet temperature reflects the tank temperature. Adjust the thermostat or mixing valve setting as necessary. Adjusting the thermostat setting (lower or higher) will not immediately affect the water temperature at the faucet. Flow a sufficient amount of water or allow a heat-up cycle to complete before making further adjustments.

SECTION VI: MAINTENANCE

WATER PIPING

On an annual basis, all piping should be checked for leakage at joints, shut-off valves, and unions.

T&P RELIEF VALVE

On an annual basis, the temperature and pressure relief valve should be checked for proper operation. First, attach a drain line to the valve to direct the water discharge to an open drain. This is very important because the temperature of the discharge could be very hot. Second, lift the lever at the end of the valve several times. The valve should operate freely and return to its original position properly. If water does not flow out of the valve, remove and inspect for corrosion or obstructions. Replace with a new valve if necessary. Do not repair the faulty valve as this may cause improper operation.

ANODE RODS

Anode rods should be inspected twice in the first year and at least yearly once a time interval for inspection has been developed. It is recommended to check the rod(s) six months after the heater is installed. If the anode rod had reduced in size by two-thirds of its original diameter of 3/4" or shows signs of pitting, it is time for replacement. Take the following steps when changing the anode rod(s):

1. Shut off water supply.
2. Open any faucet to relieve tank pressure.
3. Remove caps on water heater top; push insulation aside.
4. Use a 1 1/16" six-sided socket wrench and a breaker bar. Snap hard to break the anode rod seal.
5. Remove rod(s) and replace with new rod(s).
6. Turn water supply back on and leave faucet open until air is out of line.
7. Turn faucet off and check that new rod(s) doesn't leak.
8. Snap caps back into place.

SECTION VI: MAINTENANCE (cont.)

FLUSH THE TANK

The solar indirect water heater is glass lined. Elements in the water such as lime, iron and other minerals may accumulate in the heater. It is recommended that the tank be drained and flushed thoroughly once a year to prevent buildup in the tank.

SOLAR CONTROLLER AND COLLECTOR PANELS

The solar controller and collector panel manufacturer may have a recommended maintenance procedure. Refer to the instruction manual that was received with the solar equipment.

SECTION VII: TROUBLESHOOTING

PROBLEM	CAUSE	SOLUTION
No hot water at faucet	ECO on thermostat tripped	Determine cause of ECO trip (solar heat or electric element). Correct or replace as necessary. Reset thermostat (depress red button).
	Circulator does not operate	Check power supply
		Replace as necessary
		Check solar controller
	Improper thermostat setting	Turn thermostat to safe temperature setting
Electrical problem (relay, wiring, etc.)	Check fuse and replace	
	Check circuit breaker and reset (if applicable)	
	Check power supply	
Scale build-up	If boiler, circulator, and tank are operating satisfactorily, coil may have scale coating. See Section VI for tank flushing procedure.	
Water at faucet too hot	Thermostat set too high	Lower thermostat setting to safe level
	Tempering valve not properly set or defective	Check manufacturers instructions
Insufficient hot water	Thermostat set too low	Raise thermostat setting to safe level. See Section V
	Undersized boiler with no priority to domestic hot water	Rewire for priority
	Undersized solar collectors	Calculate proper collector surface area, orientation, and available sunlight.
	Peak use of hot water is greater than tank storage capacity	Determine peak usage, compare to tank capacity, and add additional storage (storage tank) if necessary
	Faulty tank thermostat	Replace thermostat
Scale, hard white particles from faucets, popping sound from tank	Lime, water hardness above 7 grains-120ppm	Water treatment; softener; etc.
Rust staining; bad taste and odor in water	Iron/minerals in water supply	Filtration
Rotten egg odor	Hydrogen Sulfide	Flush tank with chlorine solution and install aluminum anode rod(s)
Air from hot water fixture	Electrolysis or air introduced by water supply	Properly ground heater & replace anode rod(s). Check well pump system.
Reduction in recovery	Dip tube broken or compromised by high chlorine in water	Replace dip tube
Inlet/Outlet fitting corrosion	Galvanic corrosion of dissimilar metals	Install dielectric unions
T&P Valve dripping water	Excessive water pressure (above 150 psi)	Check incoming water supply pressure; closed loop system requires expansion tank
T&P gushing water	Excessive water temp. (above 210 °F)	Adjust or replace thermostat and T&P valve

SECTION VIII: PARTS LIST

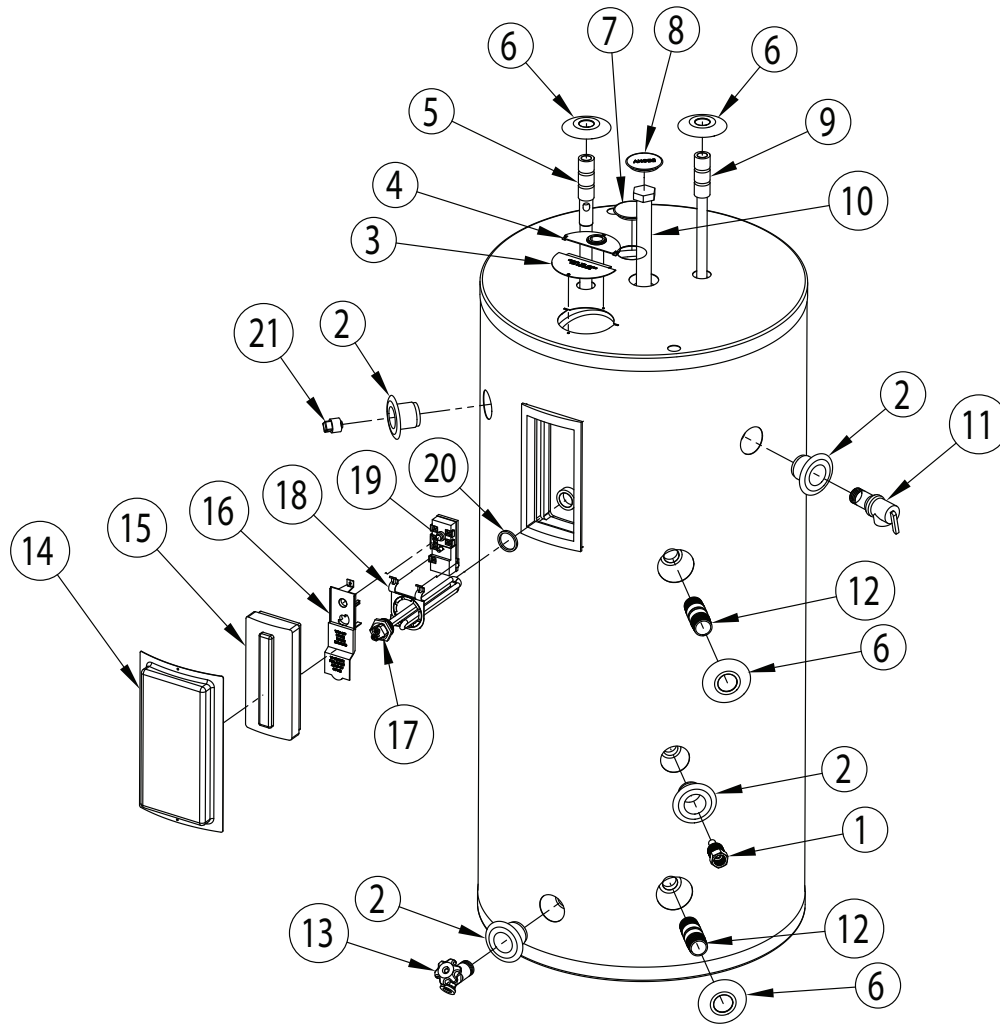

Table 8: 50SCE Parts

Part Description	
1	Sensor Immersion Well (solar)
2	Leak Detector
3	J-Box Cover
4	J-Box Cover (w/ conduit hole)
5	Hot Outlet with Anode
6	Finish Ring
7	Cap (blank)
8	Cap ("ANODE")
9	Cold Inlet with Diptube
10	Anode Rod
11	T&P Relief Valve
12	Pipe Nipple (plastic-lined)
13	Drain Valve
14	Access Cover
15	Foam Dam Cover
16	Thermostat Cover
17	Heating Element
18	Thermostat Mounting Bracket
19	Thermostat
20	Heating Element Gasket
21	Plug

SECTION VIII: PARTS LIST (cont.)

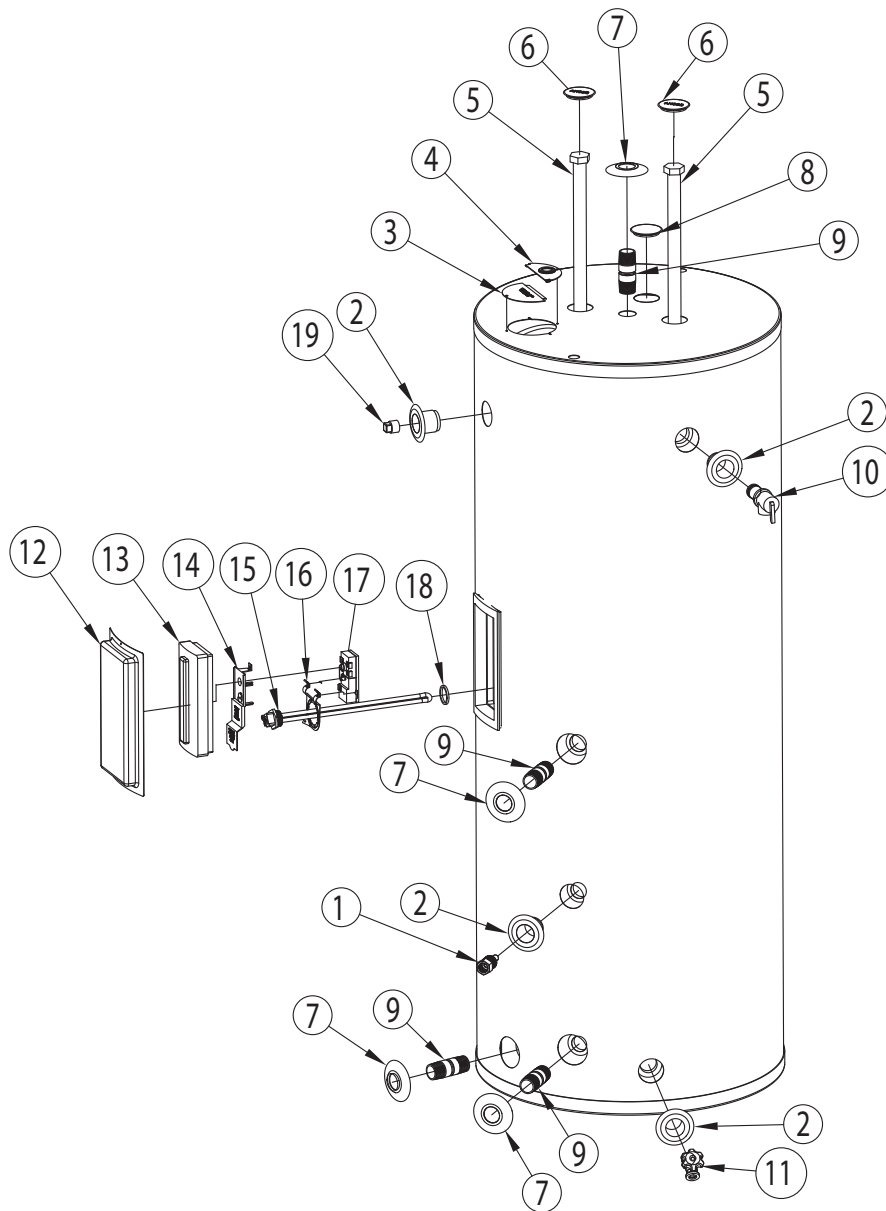

Table 9: 80SCE & 119SCE Parts

Part Description			
1	Sensor Immersion Well (solar)	10	T&P Relief Valve
2	Leak Detector	11	Drain Valve
3	J-Box Cover	12	Access Cover
4	J-Box Cover (w/ conduit hole)	13	Foam Dam Cover
5	Anode Rod	14	Thermostat Cover
6	Cap ("ANODE")	15	Heating Element
7	Finish Ring	16	Thermostat Mounting Bracket
8	Cap (blank)	17	Thermostat
9	Pipe Nipple (plastic-lined)	18	Heating Element Gasket
		19	Plug

SECTION VIII: PARTS LIST (cont.)

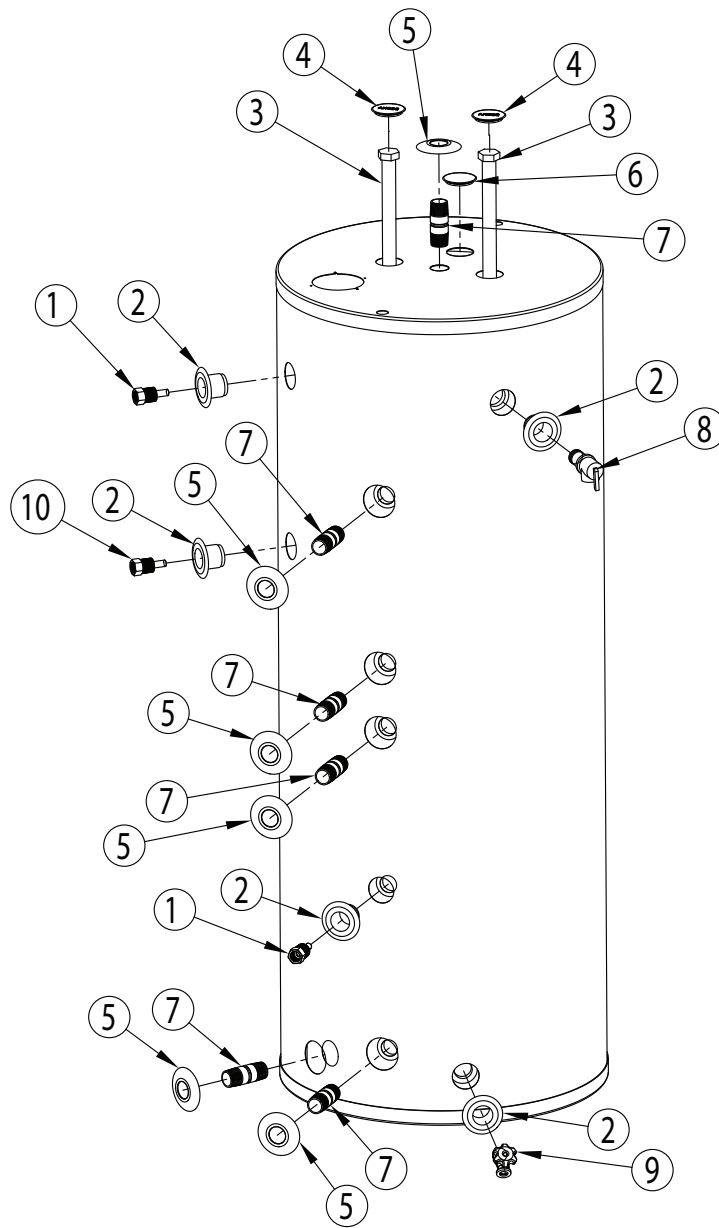

Table 10: 80SDC & 119SDC Parts

Part Description	
1	Sensor Immersion Well (solar)
2	Leak Detector
3	Anode Rod
4	Cap ("ANODE")
5	Finish Ring
6	Cap (blank)
7	Pipe Nipple (plastic-lined)
8	T&P Relief Valve
9	Drain Valve
10	Immersion Well (for aquastat)

SECTION IX: WARRANTY

LIMITED WARRANTY FOR SOLAR WATER HEATER

SolarStor™
110 S. Dickinson Street
Madison, WI 53703
Phone: 608-257-2225

WHAT DOES THIS LIMITED WARRANTY COVER?

This limited warranty applies only to the original consumer purchaser.

For water heaters installed in single family dwellings for residential use:

General Defects and Malfunctions: This warranty covers defections and malfunctions in your new water heater for a period of one year from the original installation date. We will repair or replace, at our option, any defective or malfunctioning component of the water heater. This limited warranty will terminate if you sell or otherwise transfer the water heater, or the water heater is installed at a location different from its original installation location.

Tank and Heat Exchanger (indirect coil only): We also warrant that the tank and heat exchanger will not leak due to defective materials or workmanship for six years from the date of original installation or from date of manufacture in the event the Limited Warranty Registration Card was not completed and returned to manufacturer. If the tank and heat exchanger is leaking and we have verified that the leak is due to a defect in materials and workmanship, we will replace the tank with a tank that is the nearest SolarStor™ model available at the time of replacement. If a replacement tank is provided, it will remain warranted under this section as if it were the original tank. For example, if we send you a replacement tank under this limited warranty two years after the original installation date, then the replacement tank will remain warranted for the remaining four years after the original installation date.

For all other water heaters, such as commercial use:

General Defects and Malfunctions: This warranty covers defections and malfunctions in your new water heater for a period of one year from the original installation date. We will repair or replace, at our option, any defective or malfunctioning component of the water heater. This warranty lasts for one year. Coverage terminates if you sell or otherwise transfer the water heater, or the water heater is installed in a different location.

Tank and Heat Exchanger (indirect coil only): We also warrant that the tank and heat exchanger will not leak due to defective materials or workmanship for three years from the date of original installation or from date of manufacture in the event the Limited Warranty Registration Card was not completed and returned to manufacturer. If the tank and heat exchanger is leaking and we have verified that the leak is due to a defect in materials and workmanship, we will replace the tank with a tank that is the nearest SolarStor™ model available at the time of replacement. If a replacement tank is provided, it will remain warranted under this section as if it were the original tank. For example, if we send you a replacement tank under this limited warranty two years after the original installation date, then the replacement tank will remain warranted for the remaining one year after the original installation date.

HOW DO YOU GET SERVICE UNDER THE LIMITED WARRANTY?

In order to be eligible for service under this warranty you **MUST** return the warranty registration card attached below within 30 days of purchasing the water heater.

You must have a copy of the original sales receipt at the time you request service.

To get service under this limited warranty you should contact either the dealer or installer. If dealer or installer is unknown you can call us Monday through Friday between the hours of 8 o'clock a.m. to 5 o'clock p.m. Central Time at the following number: 1-608-257-2225.

You can also write us at the following address:

SolarStor™
Warranty Support Group
110 S. Dickinson Street
Madison, WI. 53703

We will respond not later than ten days after we have received your request for service.

WHAT DOES THIS LIMITED WARRANTY NOT COVER?

This limited warranty does not cover water heaters that are or were:

- a. Incorrectly installed, especially where the installation violates state or local plumbing, housing or building codes.
- b. Operated at inappropriate settings, excessive pressures or temperatures.
- c. Exposed to adverse local conditions and specifically sediment or lime precipitation in the tank or corrosive elements in the atmosphere or unacceptable water quality.
- d. Installed outside the United States or Canada.
- e. Accidentally damaged.

Also, we will not cover the following charges, costs and losses:

- a. Any freight or delivery charges.
- b. Any removal or installation charges.
- c. Charges to return the water heater or part to the manufacturer.
- d. Water damage, loss or damage to property, inconvenience or loss of use.

WHAT WILL VOID THE LIMITED WARRANTY?

If you do any of the following, you will void this limited warranty:

- a. Fail to return the warranty registration card within 30 days.
- b. Fail to retain an original copy of your sales receipt.
- c. Fail to retain the actual rating plate from the water heater.
- d. Alter or remove the serial number.
- e. Transfer or sell the water heater.
- f. Remove the water heater from its original location and install it somewhere else
- g. Fail to follow the care and maintenance instructions provided with the water heater.
- h. Remove the anode rods.
- i. Fail to inspect and replace the anode rods (you must retain and present your paid receipts as proof of anode rod replacement).

HOW DOES STATE LAW RELATE TO THIS LIMITED WARRANTY?

This is a limited warranty. WE MAKE NO OTHER EXPRESS WARRANTIES WITH RESPECT TO THIS WATER HEATER. We will not assume, nor authorize any person to assume for us any other liability in connection with the sale or operation of this water heater. ANY IMPLIED WARRANTIES, INCLUDING MERCHANTABILITY OR FITNESS FOR A PARTICULAR APPLICATION, IMPOSED ON THIS SALE UNDER THE LAWS OF THE STATE OF SALE ARE LIMITED TO ONE YEAR. This warranty gives you specific legal rights, and you may also have other rights which vary from state to state. Some states do not allow limitations on how long an implied warranty lasts, so the above limitation may not apply to you.

WE WILL NOT BE RESPONSIBLE FOR WATER DAMAGE, LOSS OF USE OF THE UNIT, INCONVENIENCE, LOSS OR DAMAGE TO PERSONAL PROPERTY, WHETHER DIRECT OR INDIRECT, AND WHETHER ARISING IN CONTACT OR TORT. Some states do not allow the exclusion of incidental or consequential damages, so the above exclusion may not apply to you.

SolarStor • 110 South Dickinson Street • Madison, WI 53703
Telephone: 608-257-2225 • Fax: 608-257-5304